

АУЫЛ ШАРУАШЫЛЫҒЫН МЕХАНИКАЛАНДЫРУ ЖӘНЕ ЭЛЕКТРЛЕНДІРУ
МЕХАНИЗАЦИЯ И ЭЛЕКТРИФИКАЦИЯ СЕЛЬСКОГО ХОЗЯЙСТВА
AGRICULTURE MECHANIZATION AND ELECTRIFICATION

IRSTI 68.85
UDC 631.171

DOI <https://doi.org/10.37884/4-2021/10>

R.M. Kassimova^{1*}, M.Ya. Mihov², A.S. Adilsheev³

¹ Kazakh National Agrarian Research University, Almaty, Kazakhstan,
kassimova_rizvangul@mail.ru*

² Institute of Soil Science, Agrotechnologies and Plant Protection «N.Poushkarov»,
Sofia, Bulgaria, M.Mihov@abv.bg

³ Scientific Production Center of Agricultural Engineering,
Almaty, Kazakhstan, adanuar@mail.ru

INDICATORS OF A COMPREHENSIVE ASSESSMENT OF A COMBINED
AGRICULTURAL MACHINE

Abstract.

This article discusses indicators for assessing machines and the quality of mechanized work, helping to choose the best option for machines with the current large supply on the market.

The valuation of agricultural equipment and machinery is a comprehensive study carried out in order to establish its true value in a free market. In a market economy, the requirements for the quality of agricultural machinery have increased, and therefore it is necessary to substantiate (clarify) a new nomenclature of estimated indicators and their characteristics (weight, significance) and, on this basis, build an indicator for a comprehensive assessment of the effectiveness of functioning.

The scientific novelty of the research lies in the development of methods for determining the overall satisfaction coefficient of machines and assessing the quality of technological operations.

As a result of the study, the elements of the experimental research methodology for the overall satisfaction coefficient of machines and the quality assessment of technological operations for the combined unit for improving pastures and grasslands were substantiated.

Key words: *quality assessment, quality of mechanized work, machine reliability, satisfaction coefficient, experimental research methodology, combined unit, tillage.*

1. Introduction.

The current stage of development of agricultural machinery, characterized by the transition to market relations, has formed a global issue related to the exacerbation of the problem of the efficient use of agricultural machinery. The fundamental goals facing scientists in the operation of the machine and tractor fleet are to bring the quality of work to a new level, increasing the productivity of the machine - tractor unit and cost reduction per unit of output. The technical level and reliability of the machines and equipment manufactured in our country, even newly developed ones, are significantly inferior to the world level. This is primarily due to the fact that the existing test system in many cases allows for the production and operation of uncompetitive equipment, the reason for this is the imperfection of the methodological foundations of testing the equipment [1;2].

In the agricultural machinery testing system, during the period of the planned economy, standards were developed for a comprehensive assessment of machines, which made it possible to obtain a comprehensive (based on a set of indicators) quantitative assessment of the efficiency of the unit's operation based on the test results. In the conditions of a market economy, the requirements for the quality of agricultural machinery have grown, and therefore it is necessary to

justify (clarify) the new range of estimated indicators and their characteristics (weight, significance) and, on this basis, to build an indicator of a comprehensive assessment of the functioning efficiency.

The effectiveness of machines depends on the completeness of the volume of indicators and the factors with which they are associated.

When choosing the best solution, it is necessary to evaluate system performance, as well as select the best option for a machine or a set of machines that will be selected using optimization criteria.

A company that sells agricultural machinery wants to study customer satisfaction with the proposed new machine model and conducts experimental research to determine the overall level of consumer (customer) satisfaction. It characterizes a comprehensive assessment of customer satisfaction, considering the importance of the machine or its parameters and quality indicators [3;4].

2. Materials and methods.

In fig. 1 presents system indicators for a comprehensive assessment of machinery in agriculture. Some indicators are interconnected to such an extent that they can be attributed to several groups, which is not an obstacle when deciding on the introduction of a mechanism.

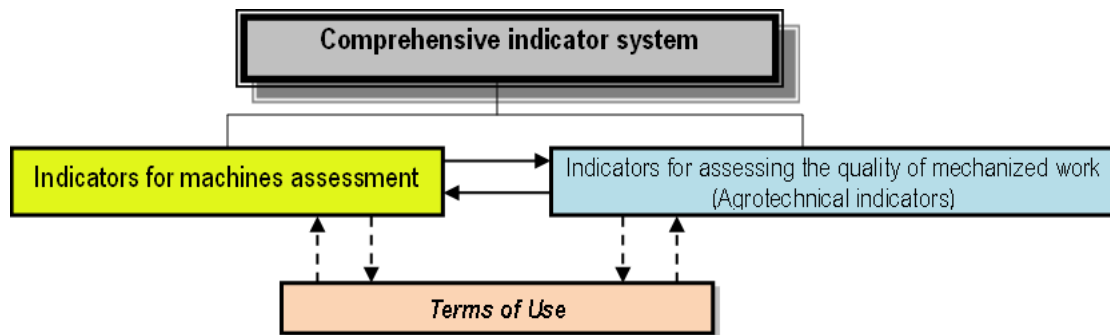

Figure 1. The indicator system for a comprehensive assessment of machines

The currently existing optimization methods make it possible to evaluate the cost-effectiveness of improving the reliability of individual machines both in the production process and consumption. However, there is still no single methodology for determining the required level of reliability from national positions, i.e. taking into account all the costs of manufacturing, operating and repairing machines, creating a reserve of spare parts, as well as crop losses due to downtime of unreliable machines. The issues of optimizing the reliability of agricultural machines used as part of complexes for cultivating specific crops, depending on their biological characteristics, are also insufficiently covered.

The system of indicators for evaluating machines in agriculture is expressed and evaluated using more properties, indicators and characteristics of their quality and reliability.

In general, quality has four sets of properties: technical, economic, social, bioecological, and reliability (Fig. 2).

The mechanization of agriculture is inextricably linked with the process of improving the culture of agricultural production - the application of the latest achievements of science and technology, the development of advanced technologies, the further intensification of agriculture, the implementation of major works on land reclamation and the chemicalization of agricultural production. Technique is the most active part of the means of production; it is of exceptional importance in creating the material and technical base of agriculture [5].

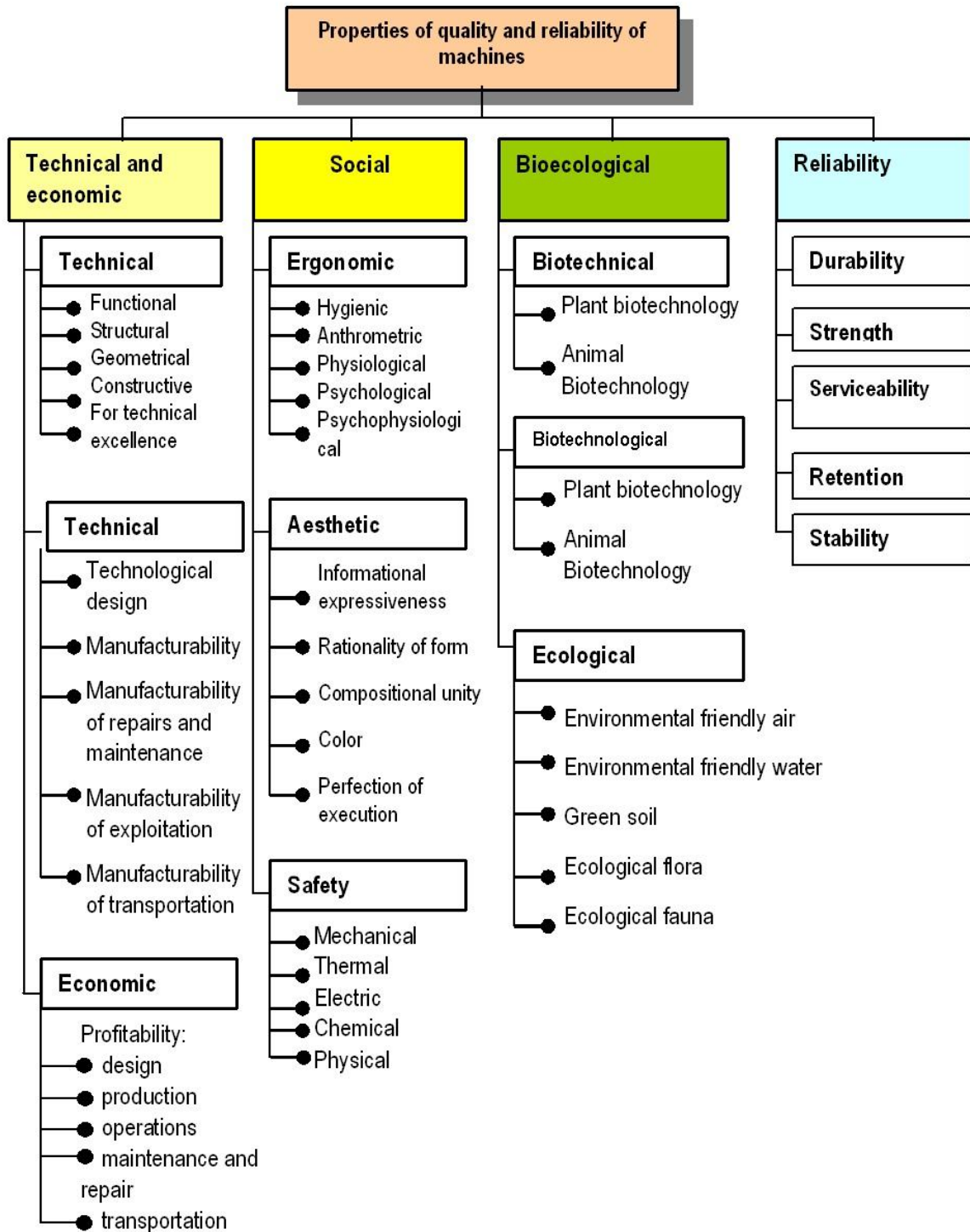

Figure 2. Classification and the relationship of the properties of machines

The indicators for assessing the quality of mechanized work should be divided into general for all types of mechanized work and for individual groups of technological processes (Fig. 3).

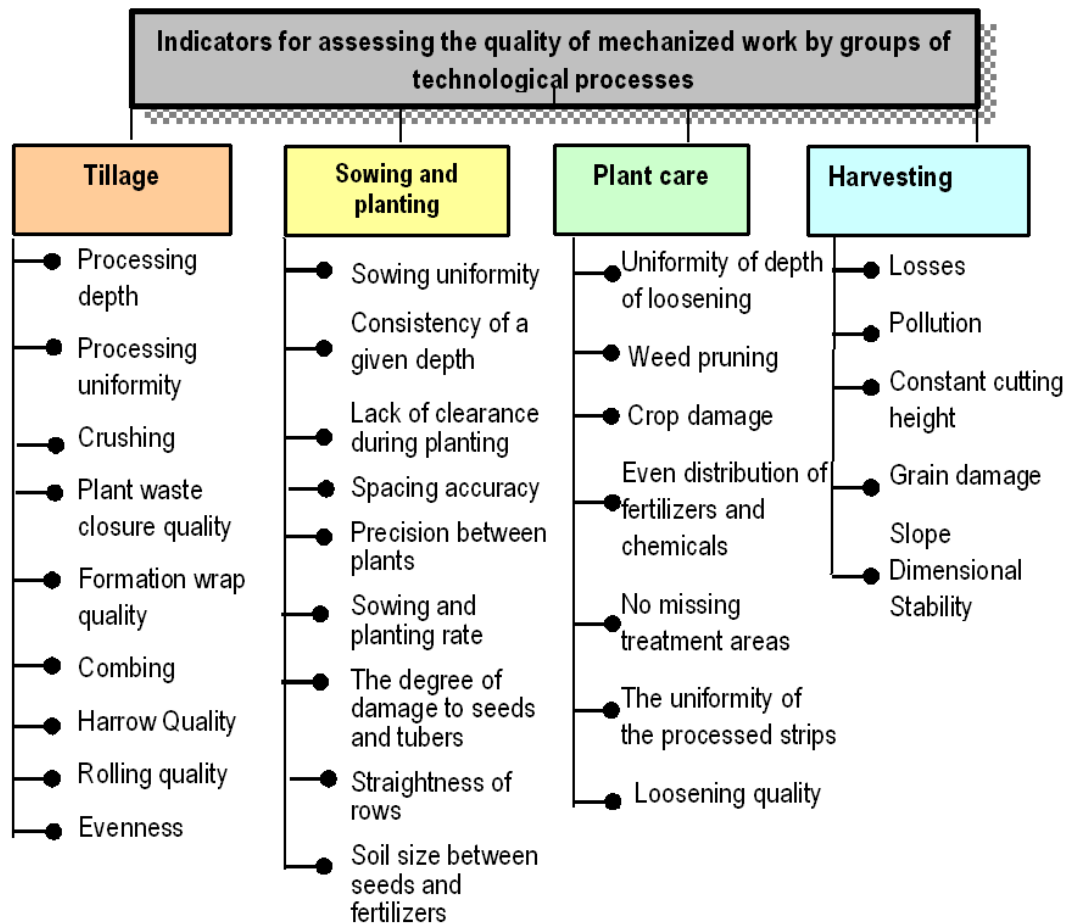

Figure 3. Indicators for assessing the quality of mechanized work

The aim of the study is to determine the overall satisfaction coefficient of the machine according to the developed experimental research methodology.

Object of study - a combined unit for the surface improvement of hayfields and pastures.

The structure, elements and interconnection of elements of the methodology of experimental research are presented in Fig. 4.

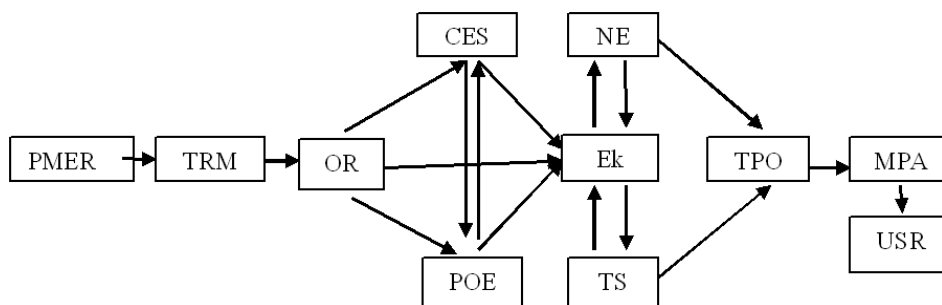

Figure 4. The structure and interconnection of the elements of the methodology of experimental research and determining the coefficient of user satisfaction :

PMER - the purpose of the methodology of experimental research; *TRM*-Tasks of the research methodology; *OR*- about the object of research; *POE* parameters for object evaluation; *CES*-conditions for experimental studies; *Ek* - experts; *NE*-number of experts; *TS* - time study; *TPO* -test procedure order; *MPA* methods for processing and analyzing survey results; *USR*-User Satisfaction Rate.

Based on the foregoing, we have developed a methodology for determining the overall satisfaction coefficient of a machine, which is proposed to be used to evaluate the operation of a combined unit for improving pastures and grasslands (Fig. 5), developed by the scientific and production center for agricultural engineering [6].

Parameters for a general assessment of the quality of the machine include general and specific indicators and are developed by analogy taking into account operating conditions:

- productivity (P_{01});
- convenience of aggregation and management (P_{02});
- the possibility of transportation (P_{03});
- maneuverability when driving across the field (P_{04});
- convenience in technological maintenance / charging, adjustments / (P_{05});
- ease of maintenance (P_{06});
- maintainability (P_{07});
- correspondence is with the safety requirements in the workplace and in service (P_{08});
- reliability (P_{09}) [7].

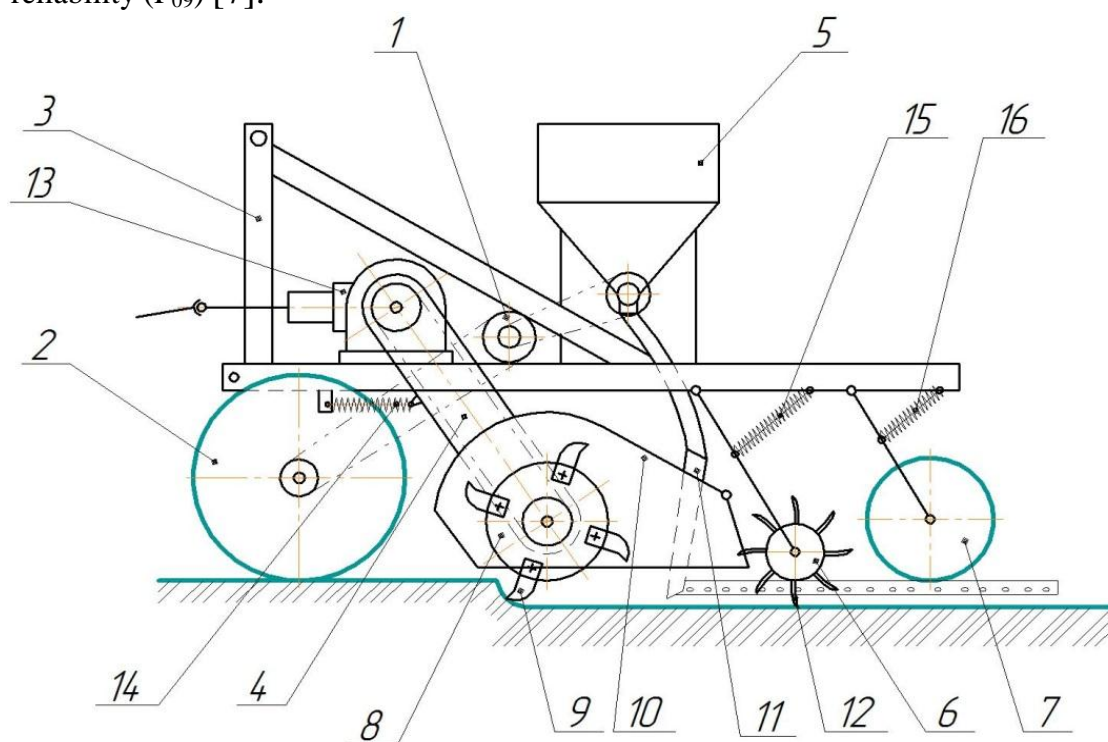

Figure 5. Structurally- technological scheme of the experimental sample of the combined unit:

1- frame; 2 - supporting-drive wheels; 3 - hitch; 4 - milling section; 5 - seed box; 5 - sowing apparatus; 6 - needle working part; 7 - packer roller; 8 - disk; 9 - L-shaped knives; 10 - a casing; 11 - seed guide ; 12 - needles; 13 - gear; 14, 15, 16 - springs.

During the study, the process of performing a technological operation according to the given parameters of the machine is evaluated by experts, i.e. engineers for the operation and maintenance of tillage and sowing machines.

To assess the quality of technological operations performed by the combined unit, an assessment was conducted on the following main parameters:

- the depth of the strip milling (P_1);
- uniformity of processing (P_2);
- fragmentation of the soil (P_3);
- uniformly s sowing (P_4);
- the constancy of a given depth of sowing (P_5);

- the evenness of the processed strips (P_6);
- quality of rolling (P_7);
- the quality of work of aeration working parts (P_8);
- soil compaction (P_9).

To determine the coefficient of satisfaction, specialists who meet the previously presented requirements were involved.

Requirements for Specialists.

Collective expert assessments express the generalized opinion of a group of specialists. To obtain quality assessments, experts must have the necessary level:

- professional competence;
- competence in the methodology of expert assessment, including knowledge of assessment methods and practical skills of their use;
- interest in participating in an expert group depending on the possibility of using the results in the expert's practical work and his involvement in the main work;
- Business qualities of an expert like objectivity, accuracy, validity of estimates, etc.;
- Objectivity in relation to the values of characteristics that are not directly related to the quality of the evaluated area;
- Specific requirements depending on the type of property being evaluated.

The reliability of group expert assessments depends on the total number and members of individual experts in the group, as well as on the competence (degree of qualification) of each of them in a particular field of knowledge.

3. Results.

The required number of experts in the group

The determination of the number of experts in a group must be subject to the following restrictive conditions:

- You should not be very small in order to avoid the influence of individual expert opinion on the quantitative assessment;
- You should not be very large in order to avoid reducing the cost of evaluations of individual experts, whose opinions differ significantly from those of the majority.

In accordance with these restrictive conditions, we can determine the required number of experts in the expert group n by the following formula:

$$n = \frac{x^2 g^2}{\varepsilon^2},$$

where, x is the argument of the probability interval, g is the coefficient of variation of expert judgment, ε is the relative sampling error.

The number of specialists for research purposes is recommended to be in the range of 6-9 people. Each expert evaluates the machine with the selected parameters, setting the rating for each parameter from 1 to 10. The expert ratings are averaged and displayed in table 1.

The procedure for determining the overall coefficient of satisfaction of machine users with the quality of production, technological and material and technical support is as follows:

- To calculate the weighting coefficients, an estimate of the importance of the parameters (P_i) is used, which determines the weighting factors for each parameter (Tables 1, 2).
- Definition of a weighted score for each of the parameters (P_i) and placement in table 2. The weighted score is obtained as follows: 9.4×12.40 and 116.56% or a weighted score of 1.1656 or 1.17 .
- Determination of the average value of a weighted estimate: $8, 48: 10 = 0, 848$, since the selected scale for evaluating the parameters is from 1 to 10.
- Comparison of the received user satisfaction rate with the base indicator, which is 75-80%. If the coefficient obtained is greater, it is assumed that the machine meets the quality requirements of consumers.

Table 1

The parameters of the evaluation of the machine, depending on the degree of importance and weighting factors

Parameters	Satisfaction rating	Weighting factors	Weighted assessment
P ₀₁	9,4	12,40%	1,17
P ₀₂	9,2	12,14%	1,12
P ₀₃	9,1	12,01 %	1,09
P ₀₄	8,0	11,74 %	1,04
P ₀₅	8,5	11,21 %	0,95
P ₀₆	8,3	10,95 %	0,91
P ₀₇	7,9	10,42 %	0,82
P ₀₈	7,3	9,63 %	0,70
P ₀₉	7,2	9,50 %	0,68
Overall assessment	$\sum_{1}^{8} 75,8$	100%	8,48

Conclusion: The satisfaction rate is $0.848 \times 100 = 84.8\%$.

Table 2

Parameters for assessing the quality of technological operations and weighting factors

Parameters	Satisfaction rating	Weight coefficient	Weighted assessment
P ₁	9,5	12,60%	1,20
P ₂	9,2	12,20%	1,12
P ₃	7,3	9,68%	0,71
P ₄	8,1	10,74%	0,87
P ₅	8,4	11,14%	0,94
P ₆	8,3	11,01%	0,91
P ₇	7,8	10,34%	0,81
P ₈	9,3	12,33%	1,15
P ₉	7,5	9,95%	0,75
Overall rating	$\sum_{1}^{8} 75,4$	100%	8,45

Conclusion: The satisfaction coefficient is $0,848 \times 100 = 84,8 \%$.

4. Main conclusions:

1. The elements of the experimental study methodology for the general satisfaction coefficient of machines for a combined unit for improving pastures and grasslands are substantiated. The combined unit for the surface improvement of pastures and hayfields, performs several technological operations in one pass: strip processing of the soil with milling working bodies, sowing grass seeds into the treated strips, rolling the soil in the treated strips and aeration processing of the inter-strip space.

2. The satisfaction rate of the combined unit for improving pastures and grasslands was determined to be 84.8% and for assessing the quality of technological operations 84.5 %. This indicates a high degree of user satisfaction with the quality of the machine and the implementation of technological operations with it.

References

1. Bejlis V.M. Obshchie tekhnicheskie i tekhnologicheskie trebovaniya k sisteme innovacionnyh mashinnyh tekhnologij i tekhniki // Nauchno - prakticheskij zhurnal «Traktora i sel'hozmashiny». – 2016. - №5. – S. 49-52.
2. Buklagin D.S. Problemy ocenki innovacionnosti produkcii // Tekhnika i oborudovaniya dlya sela. – 2013. – № 1. – S. 30-34.
3. Vereshchagin N.I. Organizaciya i tekhnologiya mekhanizirovannyh rabot v rastenievodstve / N.I. Vereshchagin, A.G. Levshin, A.N. Skorohodov i dr. 9-e izd., ster. – M.: Izdatel'skij centr «Akademiya», 2014. – s. 416.
4. YAnkovskij I.E., Kobko A.A. Kompleksnaya ocenka konkurentosposobnosti mobil'nyh sel'skohozyajstvennyh agregatov // Traktory i sel'skohozyajstvennyye mashiny № 8, 2007. S. 15-17.
5. Nukeshov S.A., Eskhozhin D.Z., Ahmetov E.S., Eskhozhin K.D., Syzdykov D.A. Razrabotka konstrukcii i obosnovanie parametrov vysevayushchego apparata dlya mineral'nyh udobrenij semyan zernovyh kul'tur i trav //Izdenister, nәtizheler -2020. -№1 (85) . - 410 s.
6. Kassimova R.M., Adilsheev A.S., Mihov M.Ya. Improving technology of pastures and grasslands development. International scientific journal «Mechanization in agriculture & conserving of the resources», Bulgaria, 2019. Vol. 65 (3), pp.111-113.
7. Fedorenko V.F., Buklagin D.S., Erohin M.N. Tekhnicheskie trebovaniya k perspektivnoj sel'skohozyajstvennoj tekhnike. – M.: FGNU «Rosinformagrotekh», 2011. – 248 s.
8. Patent for invention № 33236 RK. A method for improving meadows and pastures and a combined device for its implementation / Adilsheev AS, Zhortuylov O., Suranchiev MT, Moshanov KA, Kassimova RM; publ. 02.11.2018, bul. №41. p5.

Р.М. Касимова¹, М.Я. Михов², А.С. Адильшеев³

¹ Қазақ ұлттық аграрлық зерттеу университеті, Алматы, Қазақстан,
kassimova_rizvangul@mail.ru*

² «Н.Пушкаров» топырақтану, агротехнология және өсімдіктерді қорғау институты,
София, Болгария, M.Mihov@abv.bg

³ Агроинженерия ғылыми-өндірістік орталығы, Алматы, Қазақстан, adanuar@mail.ru

ҚҰРАМА АУЫЛ ШАРУАШЫЛЫҒЫ МАШИНАСЫН КЕШЕНДІ БАҒАЛАУ КӨРСЕТКІШТЕРІ

Аңдатпа.

Бұл мақалада қазіргі нарықтағы үлкен ұсыныстар жағдайында машиналардың ең жақсы нұсқасын таңдауға ықпал ететін машиналарды және механикаландырылған жұмыстардың сапасын бағалау көрсеткіштері қарастырылады.

Ауылшаруашылық жабдықтары мен машиналарын бағалау - бұл еркін нарық жағдайында оның нақты құнын анықтау мақсатында жүргізілетін кешенді зерттеу. Нарықтық экономика жағдайында ауыл шаруашылығы техникасының сапасына қойылатын талаптар өсті, сондықтан бағалау көрсеткіштерінің жаңа номенклатурасын және олардың сипаттамаларын негіздеу және осы негізде жұмыс істеу тиімділігін кешенді бағалау көрсеткішін құру қажет.

Зерттеудің ғылыми жаңалығы машиналардың қанағаттануының жалпы коэффициентін анықтау және технологиялық операциялардың сапасын бағалау әдістемесін жасау болып табылады.

Зерттеу нәтижесінде жайылымдар мен шабындық жерлерді жақсартуға арналған құрама агрегат үшін машиналардың қанағаттанушылығының жалпы коэффициентін эксперименттік зерттеу әдістемесінің элементтері және технологиялық операциялардың сапасын бағалау негізделді.

Кілт сөздер: сапаны бағалау, механикаландырылған жұмыстардың сапасы, мпшиналардың сенімділігі, қанағаттану коэффициенті, эксперименттік зерттеу әдістемесі, құрама агрегат, топырақты өңдеу.

Р.М. Касимова¹, М.Я. Михов², А.С. Адильшеев³

¹Казахский национальный аграрный исследовательский университет, Алматы, Казахстан, kassimova_rizvangul@mail.ru*

²Институт почвоведения, агротехнологий и защиты растений «Н.Пушкаров», София, Болгария, M.Mihov@abv.bg

³Научно-производственный центр агроинженерии, Алматы, Казахстан, adanuar@mail.ru

ПОКАЗАТЕЛИ КОМПЛЕКСНОЙ ОЦЕНКИ КОМБИНИРОВАННОЙ СЕЛЬСКОХОЗЯЙСТВЕННОЙ МАШИНЫ

Аннотация.

В данной статье рассматриваются показатели для оценки машин и качества механизированных работ, способствующие выбрать оптимальный вариант машин при нынешнем большом предложении на рынке.

Оценка сельскохозяйственного оборудования и машин представляет собой комплексное исследование, проводимое с целью установления его действительной стоимости в условиях свободного рынка. В условиях рыночной экономики выросли требования к качеству сельскохозяйственной техники, и поэтому необходимо обоснование (уточнение) новой номенклатуры оценочных показателей и их характеристик (весомость, значимость) и на этой основе построение показателя комплексной оценки эффективности функционирования.

Научная новизна исследований заключается в разработке методики для определения общего коэффициента удовлетворенности машин и оценки качества выполнения технологических операций.

В результате исследования были обоснованы элементы методики экспериментального исследования общего коэффициента удовлетворенности машин и оценки качества выполнения технологических операций для комбинированного агрегата по улучшению пастбищ и сенокосных угодий.

Ключевые слова: оценка качества, качество механизированных работ, надежность машин, коэффициент удовлетворенности, методология экспериментального исследования, комбинированный агрегат, обработка почвы.

МРНТИ 68.85.85
УДК 631.171

DOI <https://doi.org/10.37884/4-2021/11>

А.Н. Нуртулеуов, А.К. Молдажанов, А.Т. Кулмахамбетова, Д.А. Зинченко*

Казахский национальный аграрный исследовательский университет, г. Алматы, Республика Казахстан, e-mail: alish.nur.99@mail.ru

ОБОСНОВАНИЕ МЕТОДА ОПРЕДЕЛЕНИЯ ПОКАЗАТЕЛЕЙ КАЧЕСТВА ПЛОДОВ ЯБЛОК С ИСПОЛЬЗОВАНИЕМ МАШИННОГО ЗРЕНИЯ

Аннотация.

В статье рассмотрены обоснование методов и алгоритмов определения показателей качества яблок с использованием машинного зрения для дальнейшей сортировкой их на